

Silicon NPN Planar RF Transistor

Applications

For low noise and high-gain broadband amplifiers. This transistor has superior noise figure and associated gain performance at UHF, VHF, and microwave frequencies.

Features

- Low power applications
- Low noise figure
- High transition frequency

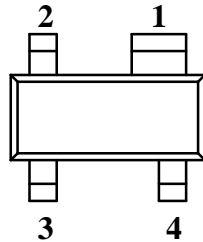

94 9279

Marking: 82 P

Plastic case (SOT 143)

1 = Collector; 2 = Emitter; 3 = Base; 4 = Emitter

Absolute Maximum Ratings

| Parameters | Symbol | Value | Unit |
|---|-----------|-------------|------------------|
| Collector-base voltage | V_{CBO} | 15 | V |
| Collector-emitter voltage | V_{CEO} | 10 | V |
| Emitter-base voltage | V_{EBO} | 2 | V |
| Collector current | I_C | 35 | mA |
| Total power dissipation $T_{amb} \leq 60^\circ\text{C}$ | P_{tot} | 200 | mW |
| Junction temperature | T_j | 150 | $^\circ\text{C}$ |
| Storage temperature range | T_{stg} | -65 to +150 | $^\circ\text{C}$ |

Maximum Thermal Resistance

| Parameters | Symbol | Maximum | Unit |
|--|------------|---------|------|
| Junction ambient on glass fibre printed board (25 x 20 x 1.5) mm ³ plated with 35 μm Cu | R_{thJA} | 450 | K/W |

Electrical DC Characteristics

 $T_{amb} = 25^{\circ}\text{C}$

| Parameters / Test Conditions | Symbol | Min. | Typ. | Max. | Unit |
|--|----------------------|------|-----------|------|---------------|
| Collector-emitter cut-off current $V_{CE} = 15\text{ V}, V_{BE} = 0$ | I_{CES} | | | 100 | μA |
| Collector-base cut-off current $V_{CB} = 10\text{ V}, I_E = 0$ | I_{CBO} | | | 100 | nA |
| Emitter-base cut-off current $V_{EB} = 1\text{ V}, I_C = 0$ | I_{EBO} | | | 1 | μA |
| Collector-emitter breakdown voltage $I_C = 1\text{ mA}, I_B = 0$ | $V_{(BR)CEO}$ | 10 | | | V |
| Collector-emitter saturation voltage $I_C = 15\text{ mA}, I_B = 1.5\text{ mA}$ | V_{CEsat} | | 0.1 | 0.4 | V |
| DC forward current transfer ratio $V_{CE} = 6\text{ V}, I_C = 5\text{ mA}$ $V_{CE} = 8\text{ V}, I_C = 20\text{ mA}$ | h_{FE} h_{FE} | 50 | 90 100 | | |

Electrical AC Characteristics

 $T_{amb} = 25^{\circ}\text{C}$

| Parameters / Test Conditions | Symbol | Min. | Typ. | Max. | Unit |
|---|----------------------|------|------------|------|------------|
| Gain bandwidth product $V_{CE} = 6\text{ V}, I_C = 5\text{ mA}, f = 500\text{ MHz}$ $V_{CE} = 8\text{ V}, I_C = 20\text{ mA}, f = 500\text{ MHz}$ | f_T f_T | | 5.5 7.5 | | GHz GHz |
| Collector-base capacitance $V_{CB} = 10\text{ V}, f = 1\text{ MHz}$ | C_{cb} | | 0.3 | | pF |
| Collector-emitter capacitance $V_{CE} = 8\text{ V}, f = 1\text{ MHz}$ | C_{ce} | | 0.2 | | pF |
| Emitter-base capacitance $V_{EB} = 0.5\text{ V}, f = 1\text{ MHz}$ | C_{eb} | | 0.7 | | pF |
| Noise figure $V_{CE} = 6\text{ V}, I_C = 5\text{ mA}, Z_S = Z_{opt}$ $f = 900\text{ MHz}$ $f = 1.75\text{ GHz}$ | F F | | 1.5 2.0 | | dB dB |
| Power gain $V_{CE} = 8\text{ V}, I_C = 20\text{ mA}, Z_S = 50\ \Omega, Z_L = Z_{Lopt}$ $f = 900\text{ MHz}$ $f = 1.75\text{ GHz}$ | G_{pe} G_{pe} | | 18 12 | | dB dB |
| Transducer gain $V_{CE} = 8\text{ V}, I_C = 20\text{ mA}, Z_0 = 50\ \Omega, f = 900\text{ MHz}$ | $ S_{21e} ^2$ | | 15 | | dB |

Dimensions of in mm

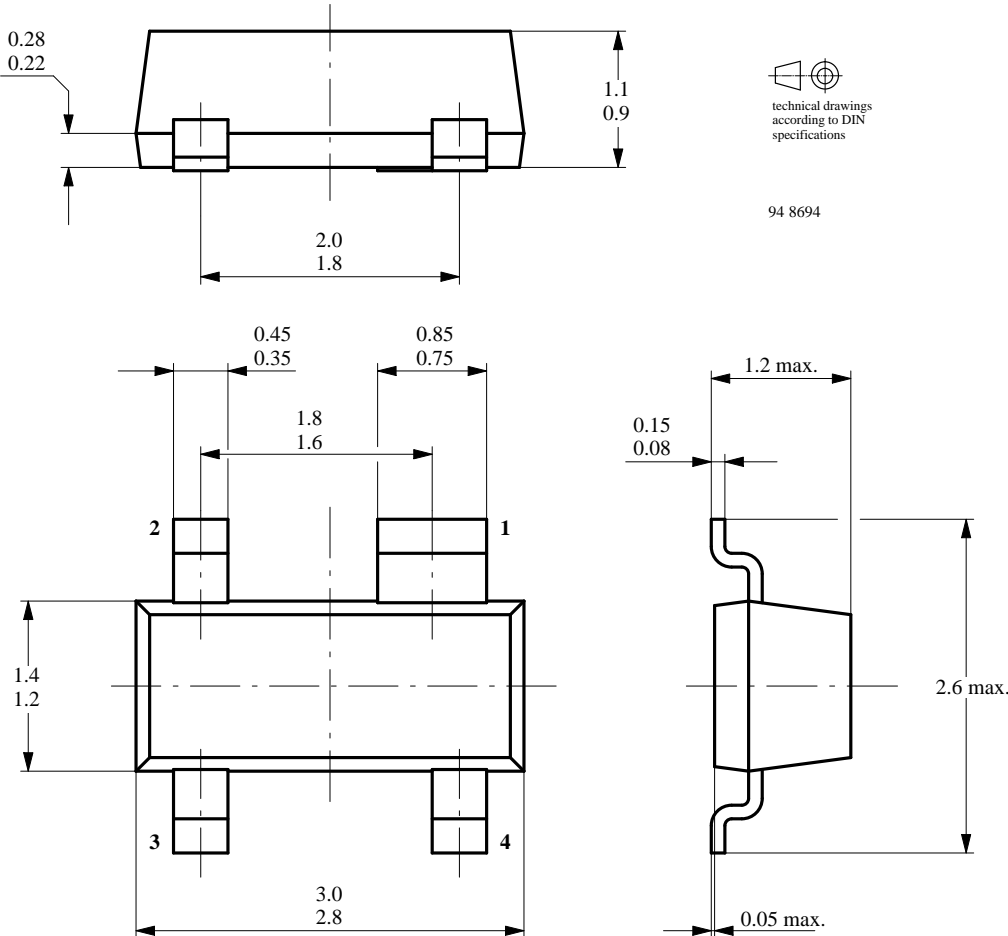

Ozone Depleting Substances Policy Statement

It is the policy of **TEMIC TELEFUNKEN microelectronic GmbH** to

1. Meet all present and future national and international statutory requirements.
2. Regularly and continuously improve the performance of our products, processes, distribution and operating systems with respect to their impact on the health and safety of our employees and the public, as well as their impact on the environment.

It is particular concern to control or eliminate releases of those substances into the atmosphere which are known as ozone depleting substances (ODSs).

The Montreal Protocol (1987) and its London Amendments (1990) intend to severely restrict the use of ODSs and forbid their use within the next ten years. Various national and international initiatives are pressing for an earlier ban on these substances.

TEMIC TELEFUNKEN microelectronic GmbH semiconductor division has been able to use its policy of continuous improvements to eliminate the use of ODSs listed in the following documents.

1. Annex A, B and list of transitional substances of the Montreal Protocol and the London Amendments respectively
2. Class I and II ozone depleting substances in the Clean Air Act Amendments of 1990 by the Environmental Protection Agency (EPA) in the USA
3. Council Decision 88/540/EEC and 91/690/EEC Annex A, B and C (transitional substances) respectively.

TEMIC can certify that our semiconductors are not manufactured with ozone depleting substances and do not contain such substances.

We reserve the right to make changes to improve technical design without further notice.

Parameters can vary in different applications. All operating parameters must be validated for each customer application by the customer. Should the buyer use TEMIC products for any unintended or unauthorized application, the buyer shall indemnify TEMIC against all claims, costs, damages, and expenses, arising out of, directly or indirectly, any claim of personal damage, injury or death associated with such unintended or unauthorized use.

TEMIC TELEFUNKEN microelectronic GmbH, P.O.B. 3535, D-74025 Heilbronn, Germany
Telephone: 49 (0)7131 67 2831, Fax Number: 49 (0)7131 67 2423